



J I A X I N G R U I C H E N



JIAXING RUICHEN EXHIBITION CO.,LTD

Tailored Solutions, Shaping Excellence – Your Trusted Shop Prop OEM/ODM Partner!

COMPANY PROFILE

Jiaying Ruichen is a leading group enterprise focusing on the image of commercial spaces across the whole industry chain. We have always been serving global customers with three systems, namely "Craftsmanship", "Digital Collaborative Management" and "Integration of Industrial Value Chain", which are used by global brand companies, large shopping malls, and shopping centers. shopping centers. After more than 20 years of accumulation and development, we have achieved excellent results, and now the international and domestic first and second-tier brands have reached long-term strategic cooperation with us to become "high-end commercial space integration solution experts and excellent service providers" for the corporate mission and goals and continue to create value for customers.



Tailored Solutions, Shaping Excellence – Your Trusted Shop Prop OEM/ODM Partner!

> MANAGEMENT (R&D) CENTER



RUICHEN-Management (R&D) Center

We create the original "5G Results Management System" and "5G Management Culture" to optimize and solve the commercial space image in a professional, digital, collaborative, and systematic manner, and insist on providing customers with value services of "integrity, responsibility, openness and win-win". Marketing, R&D and design, lean manufacturing, raw material procurement, logistics and warehousing, and after-sales service, we implement every aspect of every case perfectly and win respect. Ruichen integrates the three core business modules of "display props, mannequins, and clothes hangers" to serve our customers throughout the entire industry chain.

Precision manufacturing

From laser cutting sets to fully automatic paint finishing, the factory uses precision automatic equipment and has a rigorous prop manufacturing process. The factory is equipped with a rigorous prop manufacturing process, with self-inspection processes to complete the manufacturing and testing of the products.



Refined manufacturing

We insist on the priority of domestic materials and shorten the delivery time of our products. Creating value for our customers.



Quality Management

Long-term quality process management and supervision to ensure that each step of the production standard meets the target value.

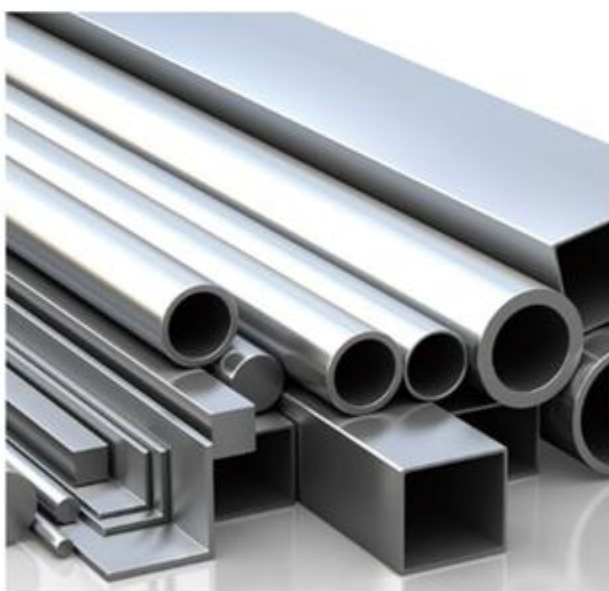

Selection of materials

The metals, acrylics, woods, and lacquers used to comply with European and national standards.



Packaging

Each product is packed and boxed to specification prior to delivery to protect the appearance and quality of the product.

> MANUFACTURE OF SHOWCASE

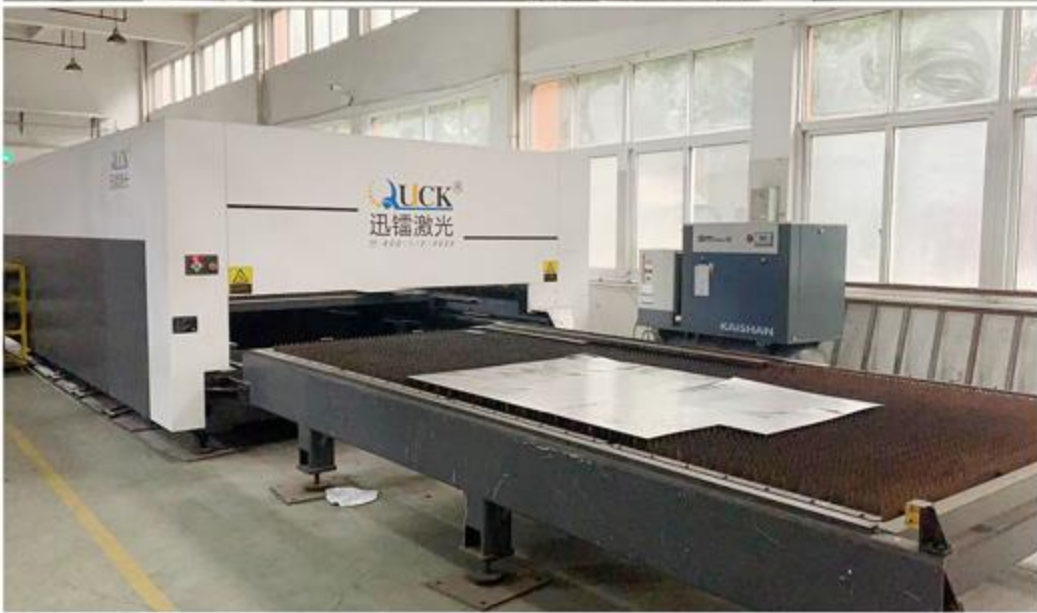

Machine Processing Center

HANS LASER laser cutting machine, LFK NAL-4000 metal grooving machine, SHACKL metal bending machine, NP330FG CNC cutting saw and other large-scale precision CNC equipment.



Production Workshop

> MANUFACTURE OF MANNEQUIN



Production Workshop

Quality Control Details

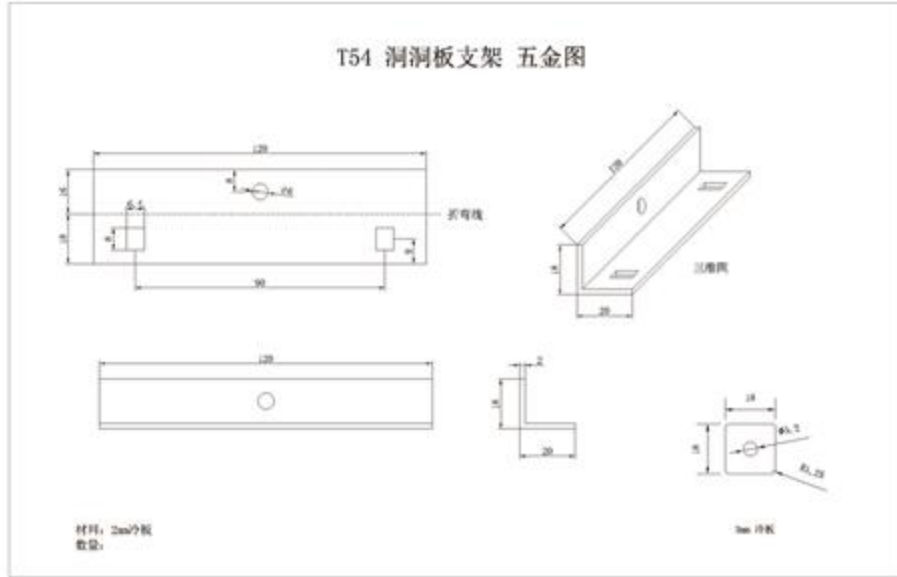

Production chart

Precise product production drawings are the first step in our rigorous prop manufacturing process. Each production step is made in strict accordance with the standards required by the drawings. Rational division of labor, efficient production, and shortened product delivery lead times.

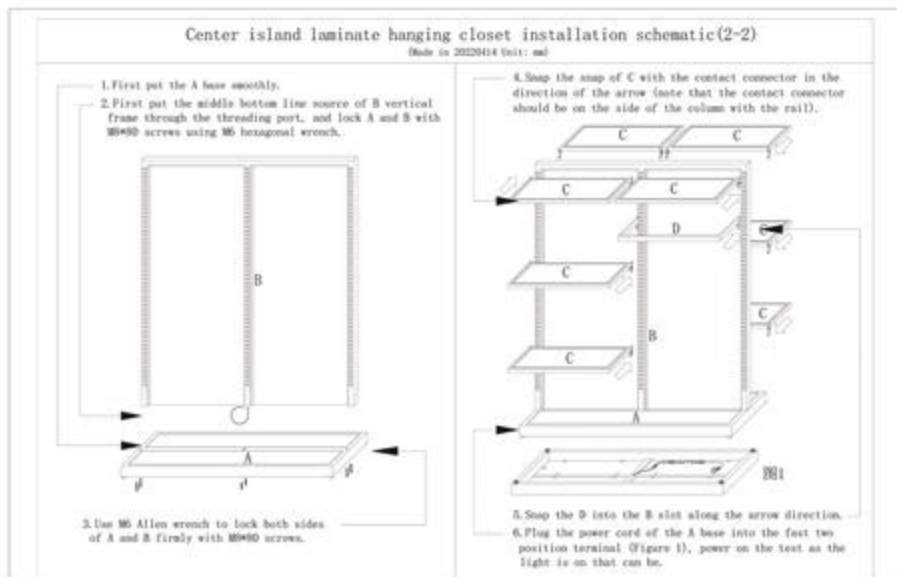

Installation diagrams

We provide each product with a detailed installation drawing paper. The installation steps are clearly illustrated, as well as a clear exploded view of the product. The customer receives the shelves and can easily build them according to the drawings, increasing the efficiency of the project.

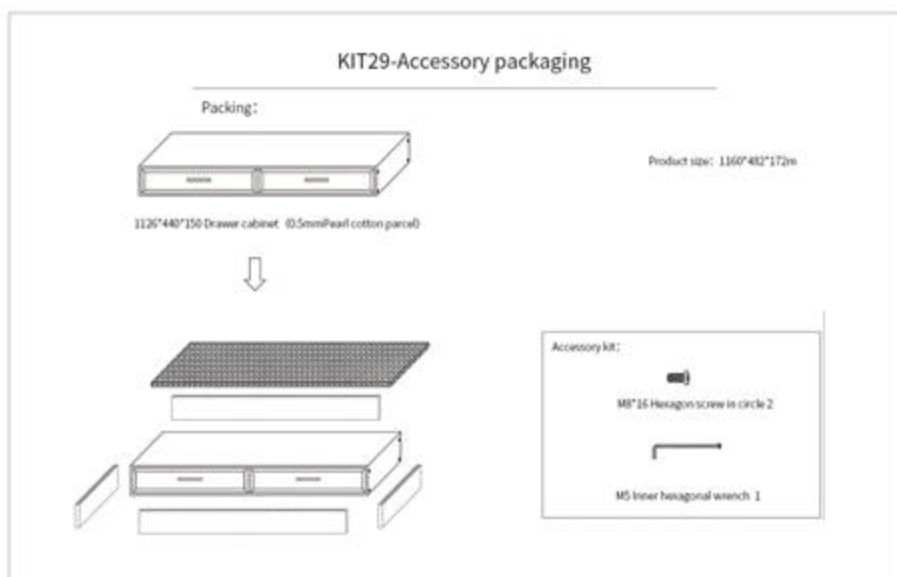

Packaging drawings

On the product packaging drawings you can see that we have clearly labeled the corresponding materials and accessories for each product. This is an important secret for our deliveries that rarely make mistakes. The packing of our products is also precisely calculated in order to save space and avoid bumps in transit.

Package delivery



Inner packaging

Each product with an individual packaging design, each part fitting just right into the box. They are accompanied by installation and accessory diagrams. The packers strictly compare the parts with the fitting diagram and refuse to miss a delivery. The laminate is protected with bubble wrap to avoid bumps and bruises. The packaging material is made of biodegradable and environmentally friendly material.



Overpacking

We have a strict system of sorting goods, checking them against a pre-made list, and delivering them in standard boxes for consignment. Each box is labeled so that the process is clear and less prone to error.



The packing in the car

Each product is pre-packed and boxed to specification prior to delivery. Protecting the appearance and quality of the product without loss.

> RUICHEN MANNEQUIN

[Welcome to contact us to view more styles](#)

Customer Brand

 lululemon

 new balance

 VICTORIA'S
SECRET

MAX&Co.

MAX&Co.



 ARC'TERYX

 asics

 JDV
EST. 2010

allbirds

Justcavalli

KRIZIA

 E.P.
ELEGANT PROSPER

CC&DD[®]

DANSKIN 

 CONVERSE

 THE
NORTH
FACE

HONMA

HOKA

 SKECHERS



Female Mannequin



Male Mannequin



Kids Mannequin



Sports mannequin



Torso Mannequin



Display Props

Female Mannequin



Male Mannequin



Sport Mannequin

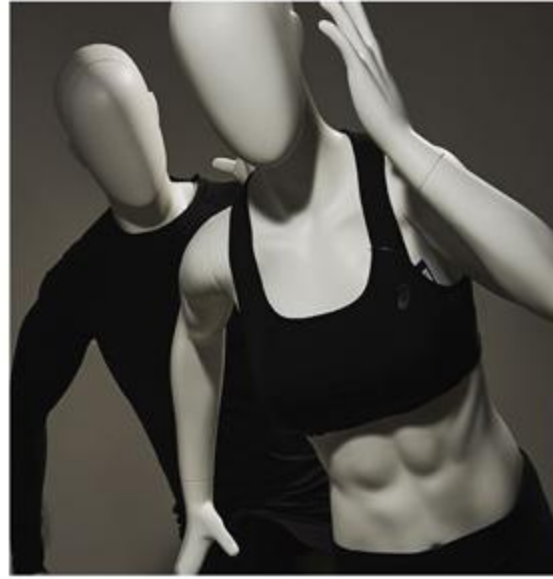

> RUICHEN MANNEQUIN [Welcome to contact us to view more styles](#)

Torso Mannequin



Kids Mannequin

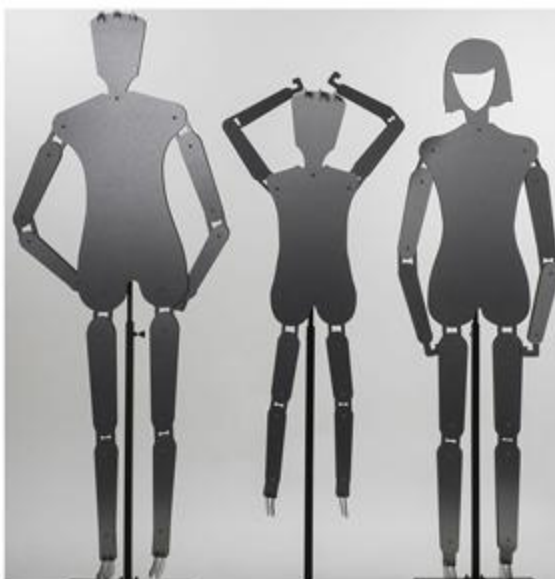

Head Legs and Hands Mannequin



> RUICHEN HANGER

[Welcome to contact us to view more styles](#)

Wooden Hanger

Can be customized with various wood materials



Plastic Hanger



> RUICHEN DISPLAY PROPS

[Welcome to contact us to view more styles](#)

Hat Display



Chest mannequin



Wooden Hand Mannequin



Tie Display



> RUICHEN DISPLAY PROPS

[Welcome to contact us to view more styles](#)

Bag Display



Shoe Display



Post Display



Jewelry Display

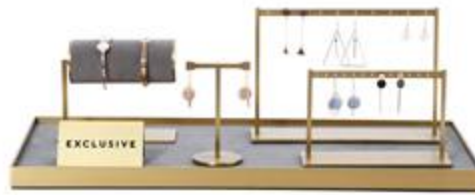
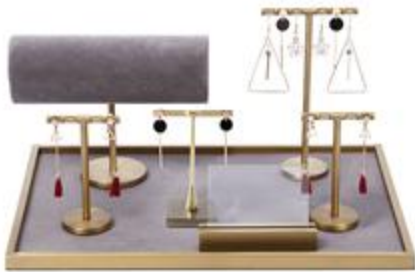

Customer Case

We have served 300+ domestic and international medium to large brand clients and have a wealth of experience in shop services.

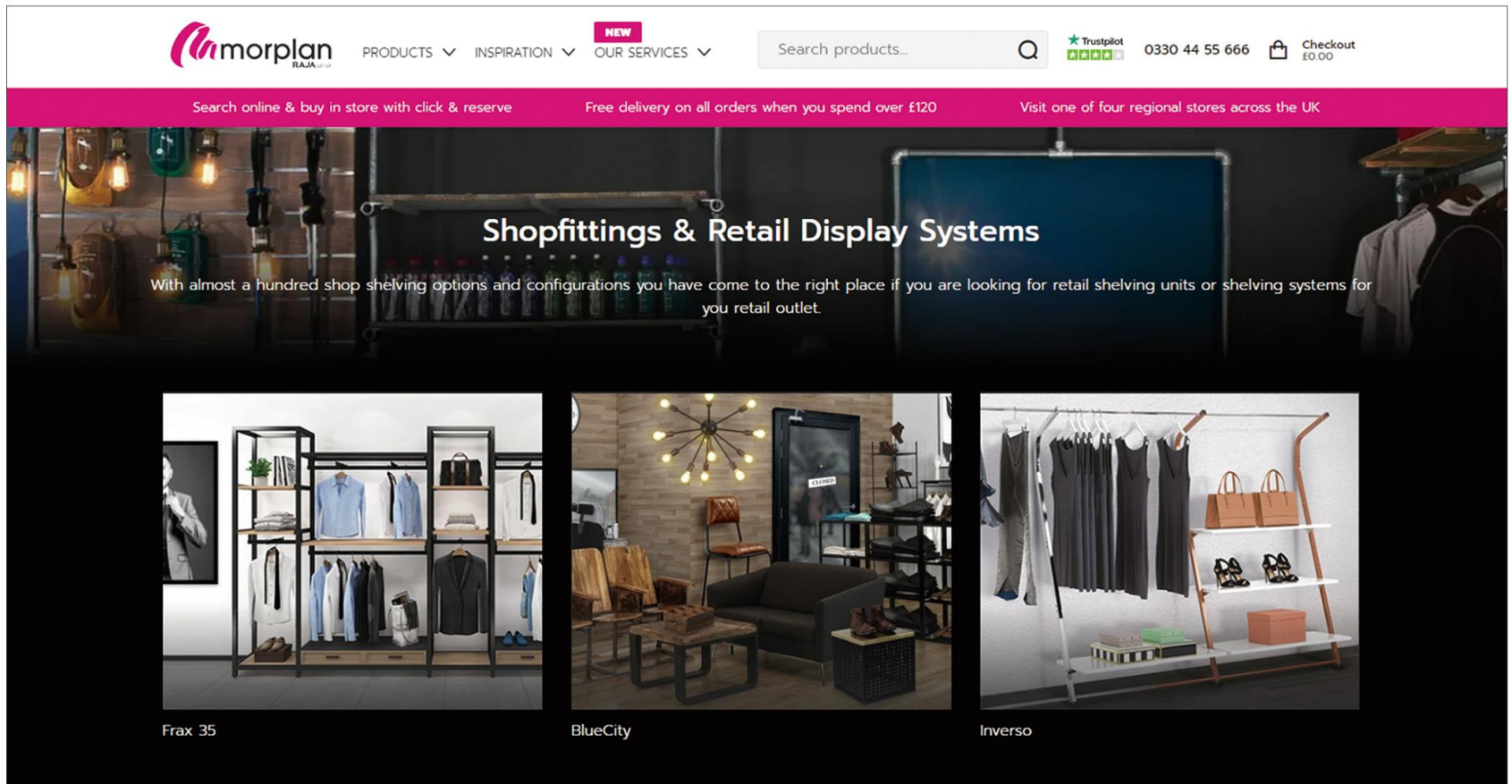

Projects:

www.morplan.com

We supply Morplan, the UK's number one supplier to the retail and fashion industry. Morplan has a history of over 170 years and has 4 physical shops in the UK.

Product photos ▶



Morplan Project Service Process:



① Project Analysis

The client is an overseas supplier to the retail industry and we took full account of the need to reduce storage pressure and transport costs by adopting a completely dismantled design for the shelving. In line with European aesthetic requirements and the ability to adapt to a wider range of shop décor styles, we used a combination of timber and metal in the design, reflecting a modern industrial and high-end style.



② Product development

The design solution features a modular splicing design between shelves and racks, which can be adapted to any shop space. The design of H-tube and T-screws enables the height of the shelves and hanging rods to be freely adjustable. The surface treatment is nano-metallic sandblasted paint for long-lasting corrosion resistance and a OE-grade environmental density board.

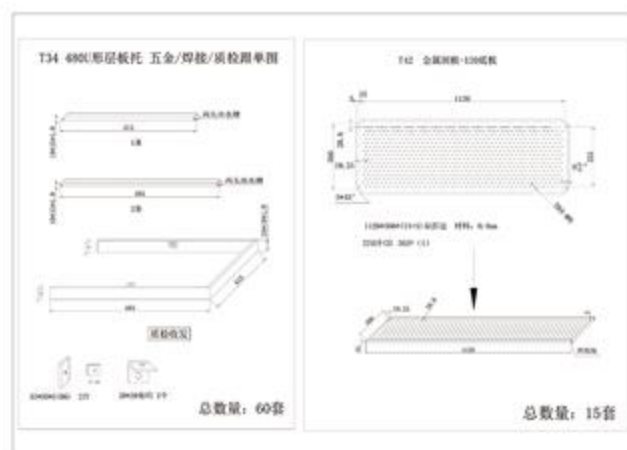

③ Production

In order to realize a flexible, easy-to-store, and diverse portfolio of shelving systems, our product designers have a high level of design competence. After several prototypes, we designed this HK series of shelves for our customers. Equipped with detailed drawings at every stage of production, not a single deviation was allowed in the production process.



④ Shipping

We have produced detailed assembly instructions for each product so that customers can easily build the shelves according to the drawings they receive. We also take great care in the packaging of our products. We choose all biodegradable materials. For the sake of saving freight costs, we have made precise calculations to save every inch of space. Each component is carefully packed to avoid bumps in transit.

Customer Case

We have served 300+ domestic and international medium to large brand clients and have a wealth of experience in shop services.



Project Description:

Project area: 150m²

Production period: 20 days

Installation time: 10 hours

Location: Atrium, 2nd floor, No.1618 Nanjing West Road (Jiu Guang Department Store), Shanghai

Services: Brand research, program design, product development, production, on-site installation

Royalcover Project Service Process:



① Brand Research

ROYALCOVER is a luxury home textile brand from Italy, advocating the concept of Italian aristocratic living and sharing luxury Italian bedding with domestic consumers. The customer base is the Chinese high-end market of business people.



② Scheme design

According to the brand research, we used rose gold brushed stainless steel for the main body of the shelves, with carved acrylic to create a scene of aristocratic royalty. In the design, the designer extracted European architectural elements using multiple arches.



③ Product development

During the product development phase, we take into account the need to reduce renovation costs for our customers while reflecting the noble aesthetics of our products. Therefore, in the process of structural dismantling, we adhere to the principles of modularity, standardization, and low wear and tear. After several prototypes to determine the production drawings.



④ Production

Our factory uses precision automatic equipment and has a rigorous prop manufacturing process, insisting on quality process management and supervision to ensure that every production standard of each stage is up to the target value.



⑤ Shipping

We have produced detailed assembly instructions for each product so that customers can easily build the shelves according to the drawings they receive.

We also take great care in the packaging of our products. We choose all biodegradable materials. For the sake of saving freight costs, we have made precise calculations to save every inch of space. Each component is carefully packed to avoid bumps in transit.



⑥ After-sales installation guide

We provide professional engineers to guide the installation process and ensure that the props are installed correctly. During the installation process, if you encounter any problems, we guarantee to provide assistance as soon as possible to solve any difficulties or doubts during the installation.

> CORPORATE CASE:GLOBAL

Customer Brand

 lululemon

SKP SELECT

NAUTICA

TIMEVALLÉE

VACHERON CONSTANTIN

JAEGER-LECOULTRE

ARC'TERYX

IWC
SCHAFFHAUSEN

JDV.
EST. 2010

allbirds

**ANNA
SUI**



CANADA GOOSE

EST. 1973
Timberland 

 Jack
Wolfskin

HIPANDA

**THE
NORTH
FACE** 

SNKRDUNK

DESCENTE

LACOSTE 



Sports Brand Store



Women's Clothing Brand Store



Men's Clothing Brand Store



Jewelry Brand Store



Shoe Brand Shop



Optical Shop



lululemon Shanghai Century Hui store



Allbirds Shanghai Taikoo Hui New Concept



Arc'Teryx Beijing Flagship

> CORPORATE CASE:GLOBAL



Vacheron Constantin Flagship Store



Jaeger-LeCoultre Flagship Store



Xi'An Timevallee Boutique



Beijing Skp Select (Beauty Zone)



Optical Shop



Royalcover Home Textile Shanghai Jiuguang Exhibition Hall

> CORPORATE CASE:GLOBAL



Canada Goose Xi'An Skps Store



JDV Shanghai Global Harbor Store



Advance Denim Exhibition Booth



Anna Sui Beijing Skp Store



Moose Knuckles Xi'An Skps Boutique



Dickies Tx Energy Store

> CORPORATE CASE:GLOBAL

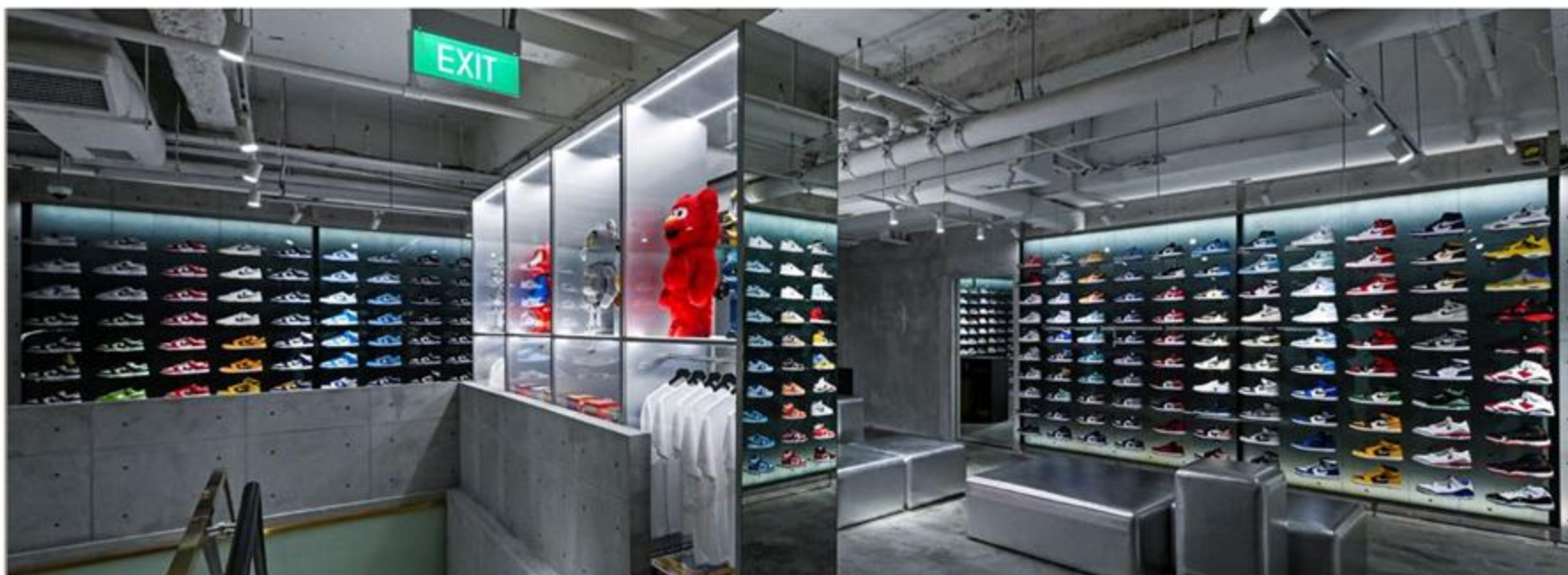

Snkr Dunk Japan



Lacoste Ftw Store Concept



Descente Store Concept

